

NOTES

- DESICCANT CAPACITY 200 LBS.
DUCAL DRIERITE STOCK # 41050
1/4 LB INDICATING DRIERITE STOCK # 21001
- MAX WORKING PRESSURE: 10 PSI

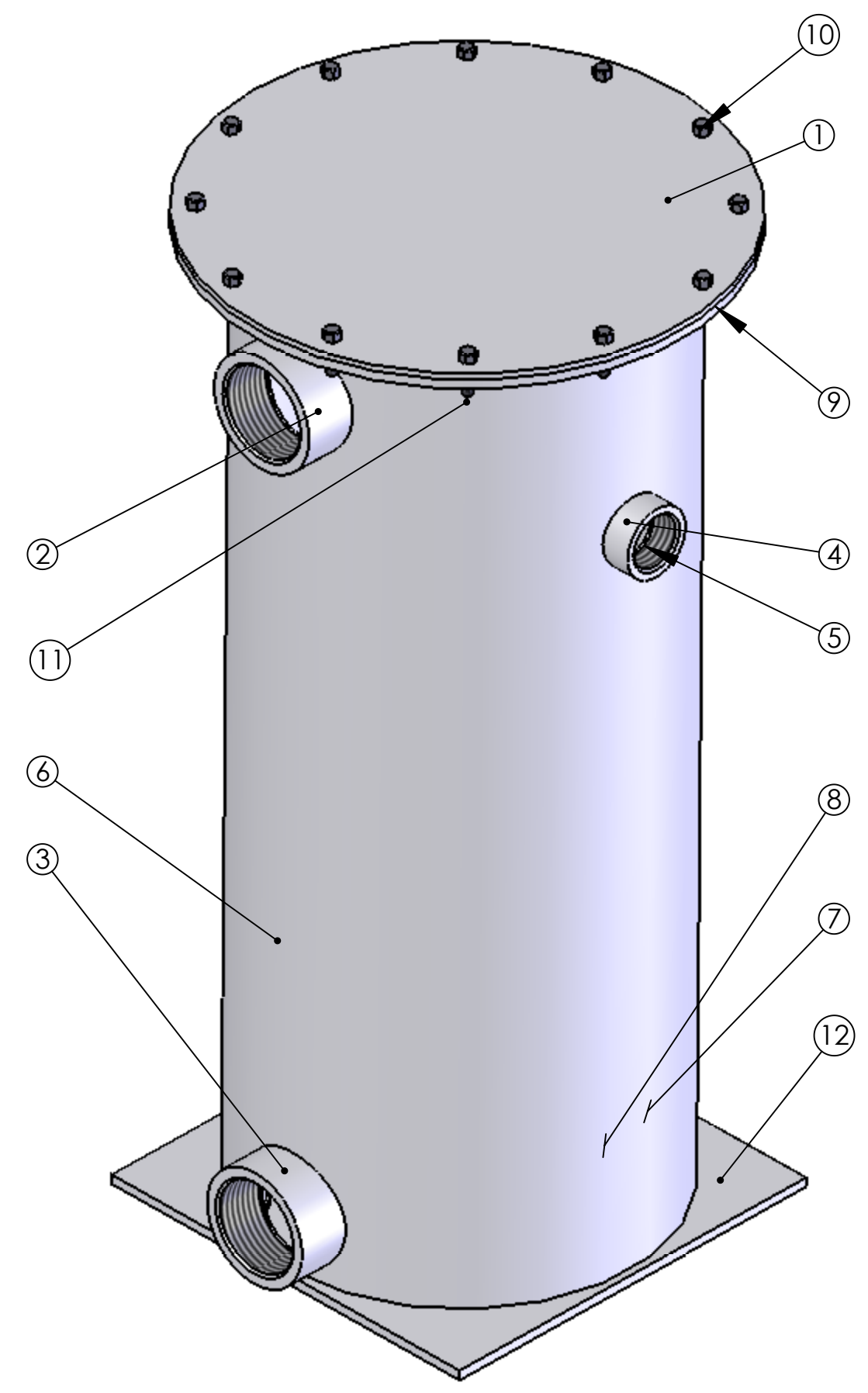
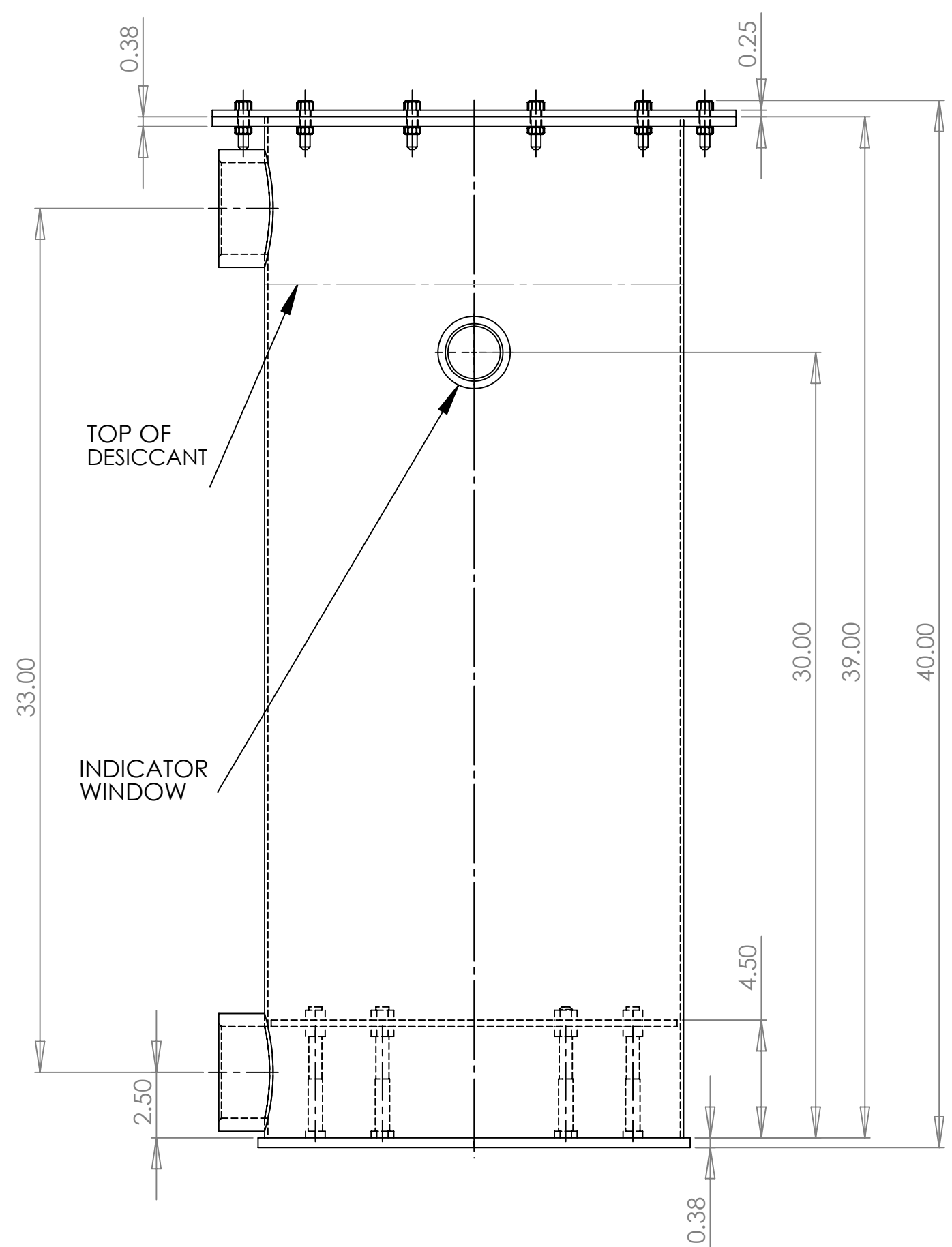
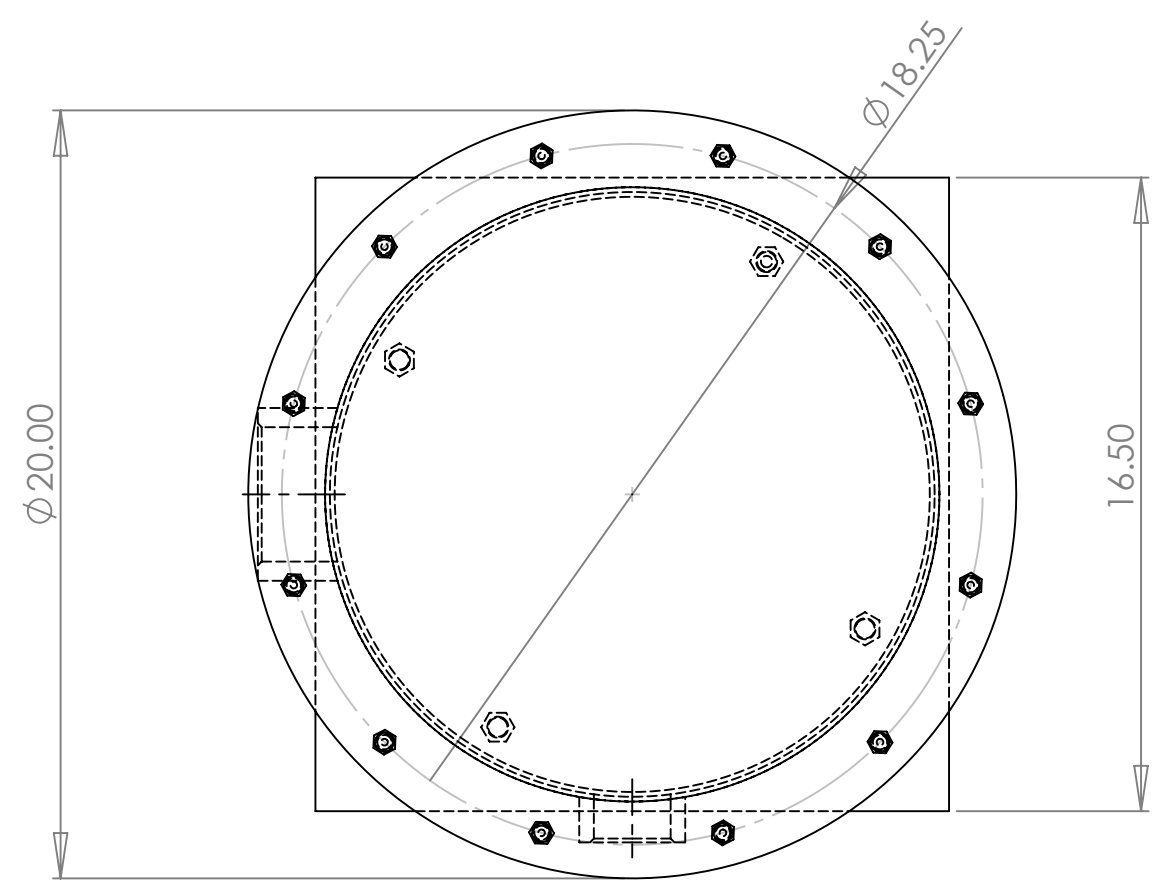

MATERIAL LIST

- TOP COVER: 1/4" SHEET; MILD STEEL
- 3" NPT OUTLET COUPLING (PURCHASE MODIFY)
- 3" NPT INLET COUPLING (PURCHASE MODIFY)
- 2" NPT COUPLING (PURCHASE MODIFY)
- 2" NPT GLASS SIGHT WINDOW (USE TEFLON SEALANT)
- TOWER: 16" OD ROLLED SHEET X .125" THICK
- Ø 16.5 10 MESH 304SS SCREEN (ATTACHED TO GRATE WITH EIGHT 3" X .032" SS WIRES)
- STEEL GRATE AND SUPPORT LEGS
- Ø 17.875" NON-ASBESTOS COMPOSITION GASKET
- (12X) 3/8-16 X 1.5" GRADE 5 BOLTS ZINC PLATED
- (12X) 3/8-16 GRADE 5 NUTS ZINC PLATED
- BOTTOM

PROPRIETARY AND CONFIDENTIAL
THE INFORMATION CONTAINED IN THIS DRAWING IS THE SOLE PROPERTY OF W.A. HAMMOND DRIERITE CO.. ANY REPRODUCTION IN PART OR AS A WHOLE WITHOUT THE WRITTEN PERMISSION OF W.A. HAMMOND DRIERITE CO. IS PROHIBITED.

UNLESS OTHERWISE SPECIFIED:		NAME	DATE
DIMENSIONS ARE IN INCHES		DRAWN	CZG 7-30-07
TOLERANCES:		CHECKED	X X
FRACTIONAL ±		ENG APPR.	X X
ANGULAR: MACH ± BEND ±		MFG APPR.	X X
TWO PLACE DECIMAL ±		Q.A.	X X
THREE PLACE DECIMAL ±		COMMENTS:	
INTERPRET GEOMETRIC TOLERANCING PER:			
MATERIAL ALL PARTS MILD STEEL UNLESS NOTED			
FINISH ENAMEL GREY			
NEXT ASSY	USED ON		
APPLICATION	DO NOT SCALE DRAWING		

W.A. HAMMOND DRIERITE CO.
P.O. Box 460 Xenia, OH 45385
Phone (937) 376-2927 Fax (937) 376-1977
www.drierite.com <mailto:drierite@aol.com>

TITLE: STORAGE TANK VENT DRIER MODEL 1200

SIZE DWG. NO. REV
C DRI-51200-ASM -

SCALE: 1:20 SHEET 1 OF 1